

Metric DIN 558 Fully Threaded Hexagon Screws/Bolts

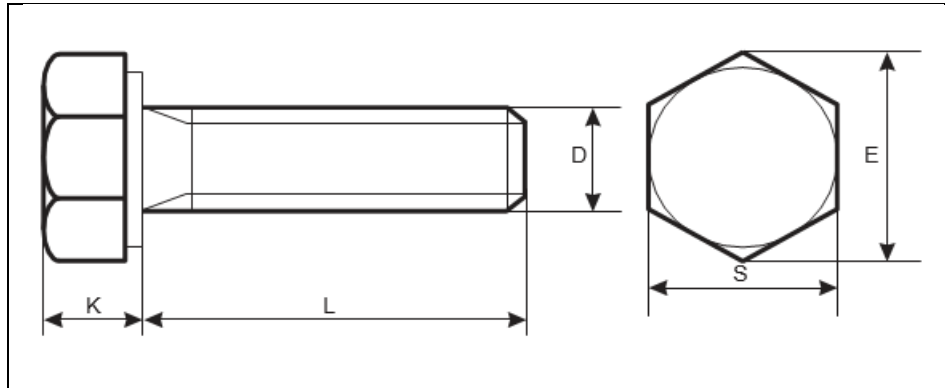

D	M5	M6	M8	M10	M12	M14	M16	M20	M24
S	8	10	13	17	19	22	24	30	36
E	8.63	10.89	14.2	18.72	20.88	23.91	26.17	32.95	39.55
K	3.5	4	5.5	7	8	9	10	13	15
L (mm)	Weight kg / 1000 pcs								
10		5.1	11.1						
12		5.1	11.1	21.2					
16	3.4	5.1	11.1	21.2	30.2				
20	3.9	5.8	12.3	23.2	33.0	48.0	83.5		
25	4.5	6.7	13.9	25.7	36.6	55.0	70.2	126.0	
30	5.1	7.5	15.5	28.2	40.2	53.9	76.9	136.0	214.0
35	5.7	8.4	17.1	30.7	43.8	62.9	88.5	147.0	229.0
40	6.4	9.2	18.7	33.2	47.4	67.9	90.9	157.0	244.0
45	7.0	10.1	20.3	35.7	51.0	72.9	97.1	167.0	259.0
50	7.6	11.0	21.8	38.2	54.5	77.9	108.0	178.0	274.0
55	8.2	11.8	23.3	40.7	58.1	82.9	110.0	188.0	289.0
60	8.8	12.7	24.8	43.4	61.7	87.9	117.0	199.0	304.0
65		13.5	26.3	45.9	65.3	92.8	123.0	209.0	319.0
70		14.4	27.8	48.5	68.9	79.8	130.0	219.0	335.0
80			30.8	53.7	76.1	107.0	144.0	240.0	363.0
90			33.8	58.9	83.3	117.0	158.0	261.0	382.0
100			36.8	64.1	90.5	127.0	172.0	282.0	401.0

All measurements are in mm

Aspen Fasteners 4807 Rockside Road, Suite 400, Independence, OH 44131 USA
www.aspenfasteners.com | aspensales@aspenfasteners.com | 1-800-479-0056

Headquarters: Independence OH USA; Montreal QC Canada;

Distribution Centers: Boston MA; Chicago IL; Cincinnati KY; Dallas TX; Denver CO; Houston TX; Jersey City NJ; Los Angeles CA; Miami FL;
 San Francisco CA; Seattle WA; Washington VA; Toronto ON; Calgary AB; Vancouver BC; Jiutepec (Temixco); Mexico City; Monterrey

Metric DIN 558 Fully Threaded Hexagon Screws/bolts have threads running the full length of the shaft, from the face side under the head to the tip. Fully threaded screws and bolts are used frequently in assemblies where grip strength is a critical feature as there are more threads and surface area in contact with the assembled parts. Typically a fully threaded bolt is tightened into a fully threaded hole of the assembled parts. Since the bolt is fully threaded, the grip is exerted along the full length of the bolt. Once fully tightened the resulting holding pressure at the head where it meets the assembly is significant and strongly resists loosening. Aspen Fasteners offers over 500,000 unique fastener products from stock in inch and metric standard in a variety of materials and finishes. The following sizes DIN 558 Fully Threaded Hexagon Screws/Bolts are available for immediate shipping from stock: Diameters ranging from M3 to M48 up to 300mm long in stainless steel A2 and A4. View parts by clicking on the following link: [DIN 558 Fully Threaded Hexagon Screws](#)

DIN (Deutsches Institut für Normung - German Institute for Standardization) standards are issued for a variety of components including industrial fasteners as Metric DIN 558 Fully Threaded Hexagon Screws/bolts. The DIN standards remain common in Germany, Europe and globally even though the transition to ISO standards is taking place. DIN standards continue to be used for parts which do not have ISO equivalents or for which there is no need for standardization. The ISO equivalent for DIN 558 Fully Threaded Hexagon Screws/Bolts is ISO 4018.

1) Mechanical properties of stainless steel for metric DIN 558 Fully Threaded Hexagon Screws/Bolts

Stainless steels can be divided into three groups of steel - austenitic, ferritic and martensitic. Austenitic steel is by far the most common type (>90% of commercial fasteners). The steel groups and strength classes are designated by a four-digit sequence of letters and numbers (eg A2-70) as shown in the following table. DIN EN ISO 3506 governs screws and nuts made from stainless steel.

Steel group	Steel grade	Strength class	Screws, Nuts and Bolts			
			Tensile strength N/mm ²	Tensile strength PSI	Dia range	Nut Load N/mm ²
Austenitic	A2 and A4	50	500	70,000	<=M39	500
		70	700	100,000	<=M20	700
		80	800	118,000	<=M20	800

The tensile stress is calculated with reference to the tensile stress area (see DIN EN ISO 3506-1979). Nuts to be paired with same grade of stainless steel screws

Steel group	Property Strength class	Made From	Characteristics
Austenitic	50	A1, A2	Soft; cold worked, turned and soft pressed fasteners
	70	A2, A4	Cold worked, normal strength formed fasteners
	80	A2, A4	Extreme cold worked, high strength, special applications

2) Chemical composition of stainless steel metric DIN 558 Fully Threaded Hexagon Screws/Bolts

Grade	USA Grade	Material designation	Material no.	C %	Si ≤ %	Mn ≤ %	Cr %	Mo %	Ni %
A 2	304	X 5Cr Ni 1810	1.4301	≤ 0.07	1.0	2.0	17.5 to 19.5	-	8.0 to 10.5
		X 2 Cr Ni 1811	1.4306	≤ 0.03	1.0	2.0	18.0 to 20.0	-	10 to 12.0
		X 8 Cr Ni 19/10	1.4303	≤ 0.07	1.0	2.0	17.0 to 19.0	-	11.0 to 13.0
A 4	316	X 5 Cr Ni Mo 1712	1.4401	≤ 0.07	1.0	2.0	16.5 to 18.5	2.0 to 2.5	10.0 to 13.0
		X 2 Cr Ni Mo 1712	1.4404	≤ 0.03	1.0	2.0	16.5 to 18.5	2.0 to 2.5	10 to 13

Aspen Fasteners 4807 Rockside Road, Suite 400, Independence, OH 44131 USA
www.aspenfasteners.com | aspensales@aspenfasteners.com | 1-800-479-0056

Headquarters: Independence OH USA; Montreal QC Canada;

Distribution Centers: Boston MA; Chicago IL; Cincinnati KY; Dallas TX; Denver CO; Houston TX; Jersey City NJ; Los Angeles CA; Miami FL; San Francisco CA; Seattle WA; Washington VA; Toronto ON; Calgary AB; Vancouver BC; Jiutepec (Temixco); Mexico City; Monterrey

3) Chemical composition of steel metric DIN 558 Fully Threaded Hexagon Screws/Bolts

PROPERTY CLASS	MATERIAL AND TREATMENT	CHEMICAL COMPOSITION LIMITS %				TEMPERING TEMP °C MIN.
		C		P	S	
		min.	max.	max.	max.	
4.6, 4.8, 5.8, 6.8	Low or medium carbon steel	-	0.55	0.05	0.06	-
8.8	Medium carbon steel quenched, tempered	0.25	0.55	0.04	0.05	425
9.8	Medium carbon steel quenched, tempered	0.25	0.55	0.04	0.05	425
10.9	Medium carbon steel additives e.g. boron, Mn, Cr or Alloy steel - quenched, tempered	0.20	0.55	0.04	0.05	425
12.9	Alloy steel - quenched, tempered	0.20	0.50	0.035	0.035	380

4) Mechanical properties of steel for metric DIN 558 Fully Threaded Hexagon Screws/Bolts

MECHANICAL PROPERTY		PROPERTY CLASS								
		4.8	5.6	5.8	6.8	8.8		9.8	10.9	12.9
						Up to M 16	Over M 16			
Tensile Strength (Rm, N/mm ²)	nom.	400	500		600	800		900	1000	1200
	min.	420	500	520	600	800	830	900	1040	1220
Vickers Hardness	min.	130	155	160	190	250	255	290	320	385
	max.	250				320	336	360	380	435
Brinell Hardness	min.	124	147	152	181	319	242	266	295	353
	max.	238				385	319	342	363	412
Rockwell Hardness	min. HR	71	79	82	89	-				
	HRC	-	-	-	-	20	23	28	32	39
	HR	95				99	-			
	max. HRC	-	-	-	-	32	34	37	39	44
Yield Stress ReL. N/mm ²	nom.	320	300	400	480	-				
	min.	340	300	420	480	-				
Stress at permanent set limit N/mm ²	nom.	-				640		720	900	1080
	min.	-				640	660	720	940	1100

Aspen Fasteners 4807 Rockside Road, Suite 400, Independence, OH 44131 USA
www.aspenfasteners.com | aspensales@aspenfasteners.com | 1-800-479-0056

Headquarters: Independence OH USA; Montreal QC Canada;

Distribution Centers: Boston MA; Chicago IL; Cincinnati KY; Dallas TX; Denver CO; Houston TX; Jersey City NJ; Los Angeles CA; Miami FL; San Francisco CA; Seattle WA; Washington VA; Toronto ON; Calgary AB; Vancouver BC; Jiutepec (Temixco); Mexico City; Monterrey



Disclaimer

Dimensional data and technical information for Metric DIN 558 Fully Threaded Hexagon Screws/Bolts was obtained from publicly available sources and not acquired through standards agencies. It has been completed and compiled for reference purposes only; where discrepancies are found they are subject to change without notice. Aspen Fasteners makes no warranties or representations regarding the accuracy and validity of the compiled information and data. Contact the relevant standards authorities for accurate and detailed information.

Aspen Fasteners 4807 Rockside Road, Suite 400, Independence, OH 44131 USA
www.aspenfasteners.com | aspensales@aspenfasteners.com | 1-800-479-0056

Headquarters: Independence OH USA; Montreal QC Canada;
Distribution Centers: Boston MA; Chicago IL; Cincinnati KY; Dallas TX; Denver CO; Houston TX; Jersey City NJ; Los Angeles CA; Miami FL;
San Francisco CA; Seattle WA; Washington VA; Toronto ON; Calgary AB; Vancouver BC; Jiutepec (Temixco); Mexico City; Monterrey