

Metric DIN 6923 Hexagon Flange Nuts

Visit our [online store](#) for product availability

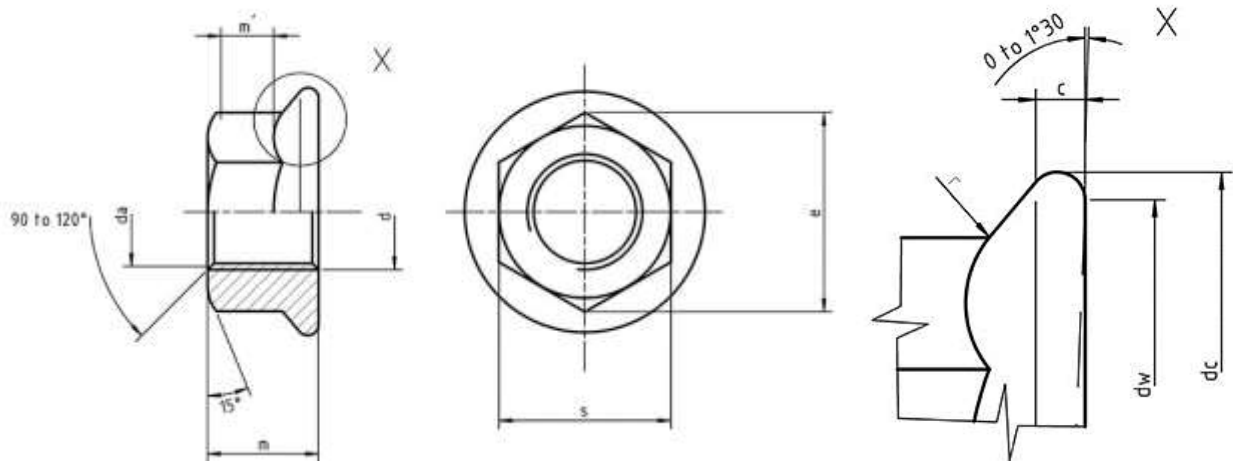

Dimensions of Metric DIN 6923 Hexagon Flange Nuts

Thread size d		M5	M6	M8	M10	M12	M14	M16	M20
		-	-	M8x1	M10x1.25	M12x1.5	M14x1.5	M16x1.5	M20x1.5
P		0.8	1	1.25	1.5	1.75	2	2	2.5
c	min.	1	1.1	1.2	1.5	1.8	2.1	2.4	3
da	min.	5	6	8	10	12	14	16	20
	max.	5.75	6.75	8.75	10.8	13	15.1	17.3	21.6
dc	max.	11.8	14.2	17.9	21.8	26	29.9	34.5	42.8
dw	min.	9.8	12.2	15.8	19.6	23.8	27.6	31.9	39.9
e	min.	8.79	11.05	14.38	16.64	20.03	23.36	26.75	32.95
m	max.	5	6	8	10	12	14	16	20
	min.	4.7	5.7	7.6	9.6	11.6	13.3	15.3	18.9
m'	min.	2.2	3.1	4.5	5.5	6.7	7.8	9	11.1
s	nominal size=max.	8	10	13	15	18	21	24	30
	min.	7.78	9.78	12.73	14.73	17.73	20.67	23.67	29.67
r	max.	0.3	0.36	0.48	0.6	0.72	0.88	0.96	1.2

Aspen Fasteners 4807 Rockside Road, Suite 400, Independence, OH 44131 USA
www.aspenfasteners.com | aspensales@aspenfasteners.com | 1-800-479-0056

Metric DIN 6923 Hexagon Flange Nuts have a circular washer like flange shaped base that increases the weight bearing surface area to distribute the load over a greater area when tightened. The flange eliminates the need to use a washer with the nut. DIN 6923 Hexagon Flange Nuts are available with or without serrations. The serrations function to act as a locking mechanism to reduce loosening due to vibrational forces. Aspen Fasteners offers the following sizes for immediate delivery from stock: Diameters ranging from M3 to M16 available in A2 and marine grade A4 stainless steel. View available parts by clicking on the following link: [DIN 6923 Hexagon Flange Nuts](#)

DIN (**D**eutsches **I**nstitut für **N**ormung - German Institute for Standardization) standards are issued for a variety of components including industrial fasteners as DIN 6923 Hexagon Flange Nuts. The DIN standards remain common in Germany, Europe and globally even though the transition to ISO standards is taking place. DIN standards continue to be used for parts which do not have ISO equivalents or for which there is no need for standardization.

1) Mechanical properties of stainless steel for metric DIN 6923 Hexagon Flange Nuts

Stainless steels can be divided into three groups of steel - austenitic, ferritic and martensitic. Austenitic steel is by far the most common type (>90% of commercial fasteners). The steel groups and strength classes are designated by a four-digit sequence of letters and numbers (eg A2-70) as shown in the following table. DIN EN ISO 3506 governs screws and nuts made from stainless steel.

Steel group	Steel grade	Strength class	Screws, Nuts and Bolts			
			Tensile strength N/mm ²	Tensile strength PSI	Dia range	Nut Load N/mm ²
Austenitic	A2 and A4	50	500	70,000	<=M39	500
		70	700	100,000	<=M20	700
		80	800	118,000	<=M20	800

The tensile stress is calculated with reference to the tensile stress area (see DIN EN ISO 3506-1979). Nuts to be paired with same grade of stainless steel screws

Steel group	Property Strength class	Made From	Characteristics
Austenitic	50	A1, A2	Soft; cold worked, turned and soft pressed fasteners
	70	A2, A4	Cold worked, normal strength formed fasteners
	80	A2, A4	Extreme cold worked, high strength, special

Aspen Fasteners 4807 Rockside Road, Suite 400, Independence, OH 44131 USA
www.aspenfasteners.com | aspensales@aspenfasteners.com | 1-800-479-0056

2) Chemical composition of stainless steel metric DIN 6923 Hexagon Flange Nuts

Grade	USA Grade	Material designation	Material no.	C %	Si ≤ %	Mn ≤ %	Cr %	Mo %	Ni %
A 2	304	X 5Cr Ni 1810	1.4301	≤ 0.07	1.0	2.0	17.5 to 19.5	-	8.0 to 10.5
		X 2 Cr Ni 1811	1.4306	≤ 0.03	1.0	2.0	18.0 to 20.0	-	10 to 12.0
		X 8 Cr Ni 19/10	1.4303	≤ 0.07	1.0	2.0	17.0 to 19.0	-	11.0 to 13.0
A 4	316	X 5 Cr Ni Mo 1712	1.4401	≤ 0.07	1.0	2.0	16.5 to 18.5	2.0 to 2.5	10.0 to 13.0
		X 2 Cr Ni Mo 1712	1.4404	≤ 0.03	1.0	2.0	16.5 to 18.5	2.0 to 2.5	10 to 13

3) Chemical composition of steel metric DIN 6923 Hexagon Flange Nuts

PROPERTY CLASS	MATERIAL AND TREATMENT	CHEMICAL COMPOSITION LIMITS %				TEMPERING TEMP °C MIN.
		C		P	S	
		min.	max.	max.	max.	
4.6, 4.8, 5.8, 6.8	Low or medium carbon steel	-	0.55	0.05	0.06	-
8.8	Medium carbon steel quenched, tempered	0.25	0.55	0.04	0.05	425
9.8	Medium carbon steel quenched, tempered	0.25	0.55	0.04	0.05	425
10.9	Medium carbon steel additives e.g. boron, Mn, Cr or Alloy steel - quenched, tempered	0.20	0.55	0.04	0.05	425
12.9	Alloy steel - quenched, tempered	0.20	0.50	0.035	0.035	380

Aspen Fasteners 4807 Rockside Road, Suite 400, Independence, OH 44131 USA
www.aspenfasteners.com | aspensales@aspenfasteners.com | 1-800-479-0056

4) Mechanical properties of steel for metric DIN 6923 Hexagon Flange Nuts

MECHANICAL PROPERTY		PROPERTY CLASS									
		4.8	5.6	5.8	6.8	8.8		9.8	10.9	12.9	
						Up to	Over				
Tensile Strength	nom.	400	500		600	800		900	100	1200	
	min.	420	500	520	600	800	830	900	104	1220	
Vickers Hardness	min.	130	155	160	190	250	255	290	320	385	
	max.	250				320	336	360	380	435	
Brinell Hardness	min.	124	147	152	181	319	242	266	295	353	
	max.	238				385	319	342	363	412	
Rockwell Hardness	min.	71	79	82	89	-					
	HRC	-	-	-	-	20	23	28	32	39	
	HR	95				99	-				
	max.	-	-	-	-	32	34	37	39	44	
Yield Stress ReL	nom.	320	300	400	480	-					
	min.	340	300	420	480	-					
Stress at permanent set limit N/mm ²	nom.	-				640		720	900	1080	
	min.	-				640	660	720	940	1100	

Disclaimer

Dimensional data and technical information for metric DIN 6923 Hexagon Flange Nuts was obtained from publicly available sources and not acquired through standards agencies. It has been completed and compiled for reference purposes only; where discrepancies are found they are subject to change without notice. Aspen Fasteners makes no warranties or representations regarding the accuracy and validity of the compiled information and data. Contact the relevant standards authorities for accurate and detailed information.