

Metric DIN 431 Hexagon Pipe Nuts

Visit our [online store](#) for product availability

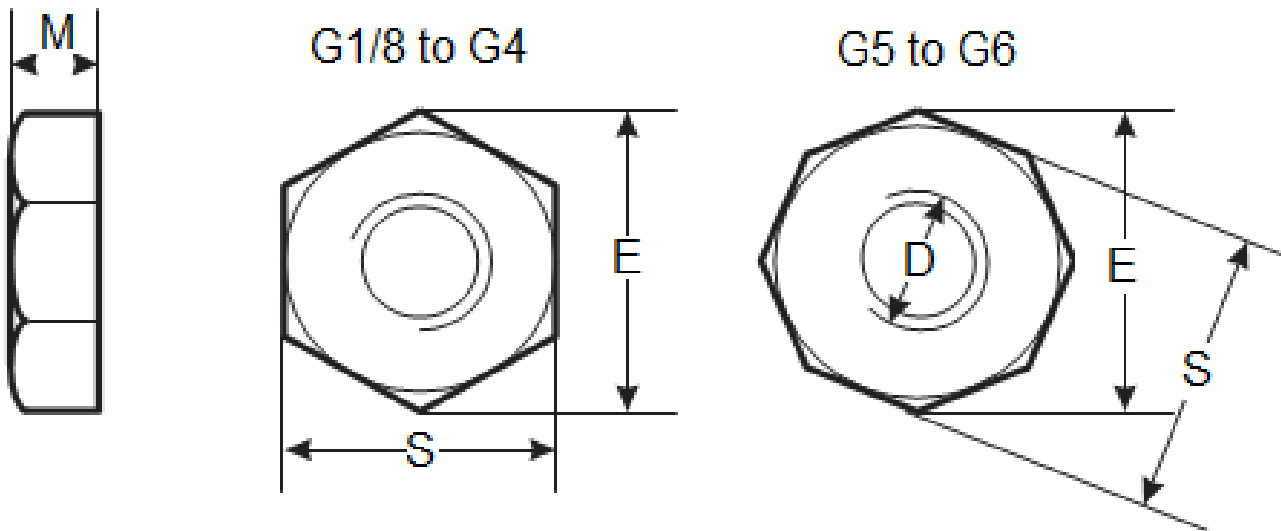

Dimensions of Metric DIN 431 Hexagon Pipe Nuts

Thread size D	E min.	M min.	M max.	S max.	S min.	weight kg/1000pcs
G 1/8	19.85	6	6.48	18	17.57	11.6
G 1/4	22.78	7	6.48	21	20.16	14.2
G 3/8	29.56	8	7.8	27	26.16	26.1
G 1/2	37.29	8	8.58	34	33	36.4
(G5/8)	37.29	9	8.58	34	33	39.8
G3/4	39.55	9	9.58	36	34	43.6
(G7/8)	45.2	10	9.58	41	40	54
G1	50.85	10	10.58	46	45	81.3
(G1 1/8)	55.37	11	10.58	50	49	95
G1 1/4	60.79	12	11.7	55	53.8	117

Aspen Fasteners 4807 Rockside Road, Suite 400, Independence, OH 44131 USA
www.aspenfasteners.com | aspensales@aspenfasteners.com | 1-800-479-0056



Thread size D	E min.	M min.	M max.	S max.	S min.	weight kg/1000pcs
G1 1/2	66.44	13	12.7	60	58.8	134
(G1 3/4)	76.93	13	13.7	70	68.1	213
G2	82.6	16	13.7	75	73.1	277
(G2 1/4)	93.56	16	16.7	85	82.8	378
G2 1/2	104.86	19	16.7	95	92.8	449
G3	116.16	22	19.84	105	102.8	554
G4	149.72	22	22.84	135	132.5	1040
G5	183.06	22	22.84	165	162.5	1330
G6	209.5	25	25.84	190	185.4	1850

Metric DIN 431 Hexagon Pipe Nuts are essentially hex jam nuts with pipe threading according to DIN ISO 228. These are thin nuts typically used in plumbing or where water supply connections occur. They are often used as a lock nut, where it is threaded up against a standard nut locking it in place or in circumstances where a standard nut is too thick for the application. Aspen Fasteners offers one of the most complete ranges of metric nuts and other inch and metric industrial fasteners for immediate delivery from stock. The following sizes of metric DIN 431 Hexagon Pipe Nuts are available for immediate shipping from stock: Diameters ranging from 1/8" to 2" in A2 and marine grade A4 stainless steel. View parts by clicking on the following link: [DIN 431 Hexagon Pipe Nuts](#)

DIN (**D**eutsches **I**nstitut für **N**ormung - German Institute for Standardization) standards are issued for a variety of components including industrial fasteners as Metric DIN 2093 Disc Spring Washers. The DIN standards remain common in Germany, Europe and globally even though the transition to ISO standards is taking place. DIN standards continue to be used for parts which do not have ISO equivalents or for which there is no need for standardization.

Aspen Fasteners 4807 Rockside Road, Suite 400, Independence, OH 44131 USA
www.aspenfasteners.com | aspensales@aspenfasteners.com | 1-800-479-0056

Headquarters: Independence OH USA; Montreal QC Canada;
Distribution Centers: Boston MA; Chicago IL; Cincinnati KY; Dallas TX; Denver CO; Houston TX; Jersey City NJ; Los Angeles CA; Miami FL; San Francisco CA; Seattle WA; Washington VA; Toronto ON; Calgary AB; Vancouver BC; Jiutepec (Temixco); Mexico City; Monterrey



1) Mechanical properties of stainless steel for metric DIN 431 Hexagon Pipe Nuts

Stainless steels can be divided into three groups of steel - austenitic, ferritic and martensitic. Austenitic steel is by far the most common type (>90% of commercial fasteners). The steel groups and strength classes are designated by a four-digit sequence of letters and numbers (eg A2-70) as shown in the following table. DIN EN ISO 3506 governs screws and nuts made from stainless steel.

Steel group	Steel grade	Strength class	Screws, Nuts and Bolts			
			Tensile strength N/mm ²	Tensile strength PSI	Dia range	Nut Load N/mm ²
Austenitic	A2 and A4	50	500	70,000	<=M39	500
		70	700	100,000	<=M20	700
		80	800	118,000	<=M20	800

The tensile stress is calculated with reference to the tensile stress area (see DIN EN ISO 3506-1979). Nuts to be paired with same grade of stainless steel screws

Steel group	Property Strength class	Made From	Characteristics
Austenitic	50	A1, A2	Soft; cold worked, turned and soft pressed fasteners
	70	A2, A4	Cold worked, normal strength formed fasteners
	80	A2, A4	Extreme cold worked, high strength, special applications

Aspen Fasteners 4807 Rockside Road, Suite 400, Independence, OH 44131 USA
www.aspenfasteners.com | aspensales@aspenfasteners.com | 1-800-479-0056

Headquarters: Independence OH USA; Montreal QC Canada;
 Distribution Centers: Boston MA; Chicago IL; Cincinnati KY; Dallas TX; Denver CO; Houston TX; Jersey City NJ; Los Angeles CA; Miami FL;
 San Francisco CA; Seattle WA; Washington VA; Toronto ON; Calgary AB; Vancouver BC; Jiutepec (Temixco); Mexico City; Monterrey



2) Chemical composition of stainless steel metric DIN 431 Hexagon Pipe Nuts

Grade	USA Grade	Material designation	Material no.	C %	Si ≤ %	Mn ≤ %	Cr %	Mo %	Ni %
A 2	304	X 5Cr Ni 1810	1.4301	≤ 0.07	1.0	2.0	17.5 to 19.5	-	8.0 to 10.5
		X 2 Cr Ni 1811	1.4306	≤ 0.03	1.0	2.0	18.0 to 20.0	-	10 to 12.0
		X 8 Cr Ni 19/10	1.4303	≤ 0.07	1.0	2.0	17.0 to 19.0	-	11.0 to 13.0
A 4	316	X 5 Cr Ni Mo 1712	1.4401	≤ 0.07	1.0	2.0	16.5 to 18.5	2.0 to 2.5	10.0 to 13.0
		X 2 Cr Ni Mo 1712	1.4404	≤ 0.03	1.0	2.0	16.5 to 18.5	2.0 to 2.5	10 to 13

3) Chemical composition of steel metric DIN 431 Hexagon Pipe Nuts

PROPERTY CLASS	MATERIAL AND TREATMENT	CHEMICAL COMPOSITION LIMITS %				TEMPERING TEMP °C MIN.
		C		P	S	
		min.	max.	max.	max.	
4.6, 4.8, 5.8, 6.8	Low or medium carbon steel	-	0.55	0.05	0.06	-
8.8	Medium carbon steel quenched, tempered	0.25	0.55	0.04	0.05	425
9.8	Medium carbon steel quenched, tempered	0.25	0.55	0.04	0.05	425
10.9	Medium carbon steel additives e.g. boron, Mn, Cr or Alloy steel - quenched, tempered	0.20	0.55	0.04	0.05	425
12.9	Alloy steel - quenched, tempered	0.20	0.50	0.035	0.035	380

Aspen Fasteners 4807 Rockside Road, Suite 400, Independence, OH 44131 USA
www.aspenfasteners.com | aspensales@aspenfasteners.com | 1-800-479-0056

Headquarters: Independence OH USA; Montreal QC Canada;
 Distribution Centers: Boston MA; Chicago IL; Cincinnati KY; Dallas TX; Denver CO; Houston TX; Jersey City NJ; Los Angeles CA; Miami FL;
 San Francisco CA; Seattle WA; Washington VA; Toronto ON; Calgary AB; Vancouver BC; Jiutepec (Temixco); Mexico City; Monterrey



4) Mechanical properties of steel for metric DIN 431 Hexagon Pipe Nuts

MECHANICAL PROPERTY		PROPERTY CLASS									
		4.8	5.6	5.8	6.8	8.8		9.8	10.9	12.9	
						Up to M 16	Over M 16				
Tensile Strength (Rm, N/mm ²)	nom.	400	500		600	800		900	1000	1200	
	min.	420	500	520	600	800	830	900	1040	1220	
Vickers Hardness	min.	130	155	160	190	250	255	290	320	385	
	max.	250				320	336	360	380	435	
Brinell Hardness	min.	124	147	152	181	319	242	266	295	353	
	max.	238				385	319	342	363	412	
Rockwell Hardness	min. HR	71	79	82	89	-					
	HRC	-	-	-	-	20	23	28	32	39	
	HR	95				99	-				
	max. HRC	-	-	-	-	32	34	37	39	44	
Yield Stress ReL. N/mm ²	nom.	320	300	400	480	-					
	min.	340	300	420	480	-					
Stress at permanent set limit N/mm ²	nom.	-				640		720	900	1080	
	min.	-				640	660	720	940	1100	

Disclaimer

Dimensional data and technical information for Metric DIN 431 Hexagon Pipe Nuts was obtained from publicly available sources and not acquired through standards agencies. It has been completed and compiled for reference purposes only; where discrepancies are found they are subject to change without notice. Aspen Fasteners makes no warranties or representations regarding the accuracy and validity of the compiled information and data. Contact the relevant standards authorities for accurate and detailed information.

Aspen Fasteners 4807 Rockside Road, Suite 400, Independence, OH 44131 USA
www.aspenfasteners.com | aspensales@aspenfasteners.com | 1-800-479-0056

Headquarters: Independence OH USA; Montreal QC Canada;
Distribution Centers: Boston MA; Chicago IL; Cincinnati KY; Dallas TX; Denver CO; Houston TX; Jersey City NJ; Los Angeles CA; Miami FL; San Francisco CA; Seattle WA; Washington VA; Toronto ON; Calgary AB; Vancouver BC; Jiutepec (Temixco); Mexico City; Monterrey