

## Metric DIN 553 Slotted Set Screws with Cone Point

Visit our [online store](#) for product availability

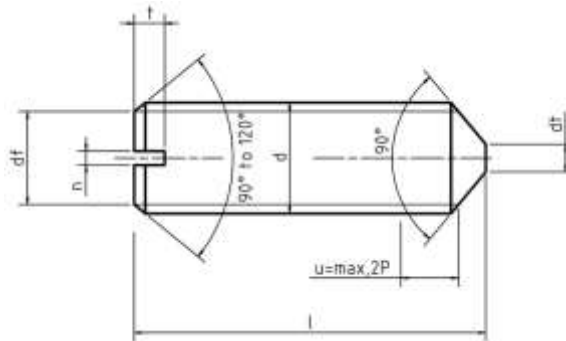

Dimensions of Metric DIN 553 Slotted Set Screws with Cone Point

Thread d			M1	M1.2	M1.4	M1.6	M2	M2.5	M3	(M3.5)	M4	M5	M6	M8	M10	M12
P			0.25	0.25	0.3	0.35	0.4	0.45	0.5	0.6	0.7	0.8	1	1.25	1.5	1.8
df	approx.		Minor thread diameter													
dt	min.		-	-	-	-	-	-	-	-	-	-	-	-	-	-
	max.		0.1	0.12	0.14	0.16	0.2	0.25	0.3	0.35	0.4	0.5	1.5	2	2.5	3
n	nominal		0.2	0.2	0.2	0.25	0.25	0.4	0.4	0.5	0.6	0.8	1	1.2	1.6	2
	min.		0.26	0.26	0.26	0.31	0.31	0.46	0.46	0.56	0.66	0.86	1.06	1.26	1.66	2.1
	max.		0.4	0.4	0.4	0.45	0.45	0.6	0.6	0.7	0.8	1	1.2	1.51	1.91	2.3
t	nominal =min.		0.4	0.4	0.48	0.56	0.64	0.72	0.8	0.96	1.12	1.25	1.6	2	2.4	2.8
	max.		0.52	0.52	0.63	0.74	0.84	0.95	1.05	1.21	1.42	1.63	2	2.5	3	3.6
l			weight kg/1000pcs													
nominal	min.	max.														
2	1.8	2.2	0.007	0.011	0.015	0.02										
2.5	2.3	2.7	0.009	0.014	0.019	0.026										
3	2.8	3.2	0.011	0.017	0.023	0.032	0.045	0.07								
4	3.7	4.3	0.015	0.024	0.031	0.046	0.065	0.1	0.13							
5	4.7	5.3			0.04	0.06	0.085	0.13	0.17	0.23						
6	5.7	6.3				0.074	0.11	0.16	0.21	0.29	0.36					
8	7.7	8.3					0.14	0.22	0.29	0.4	0.51	0.77	1.04			
10	9.7	10.3						0.28	0.37	0.51	0.67	1.02	1.44	2.65		
12	12	12.4							0.45	0.62	0.82	1.27	1.84	3.25	4.6	
14	14	14.4								0.73	0.97	1.51	2.24	3.85	5.6	
16	16	16.4								0.85	1.12	1.76	2.64	4.45	6.6	

Aspen Fasteners 4807 Rockside Road, Suite 400, Independence, OH 44131 USA  
[www.aspenfasteners.com](http://www.aspenfasteners.com) | [aspensales@aspenfasteners.com](mailto:aspensales@aspenfasteners.com) | 1-800-479-0056

Thread d			M1	M1.2	M1.4	M1.6	M2	M2.5	M3	(M3.5)	M4	M5	M6	M8	M10	M12
l			weight kg/1000pcs													
nominal	min.	max.														
20	20	20.4										2.25	3.44	5.65	8.6	
25	25	25.4													11.1	
30	30	30.4													13.6	
35	35	35.5													16.1	

Metric DIN 553 are slotted set screws with cone point. These are headless screws with a slot cut out on one end allowing for easy tightening with a slotted screwdriver and are typically made of steel or stainless steel. Set screws are typically part of an assembly and when tightened exert a compressional force through the point against the surface of an inner object. Aspen Fasteners offers the following sizes for immediate delivery from stock: Diameters ranging from M6 to M10. View available parts by clicking on the following link: [DIN 553 Slotted Set Screws with Cone Point](#)

DIN (**D**eutsches **I**nstitut für **N**ormung - German Institute for Standardization) standards are issued for a variety of components including industrial fasteners as metric DIN 553 Slotted Set Screws with Cone Point. The DIN standards remain common in Germany, Europe and globally even though the transition to ISO standards is taking place. DIN standards continue to be used for parts which do not have ISO equivalents or for which there is no need for standardization. The ISO equivalent for DIN 553 Slotted Set Screws with Cone Point is ISO 7434.

### 1) Mechanical properties of stainless steel for metric DIN 553 Slotted Set Screws with Cone Point

Stainless steels can be divided into three groups of steel - austenitic, ferritic and martensitic. Austenitic steel is by far the most common type (>90% of commercial fasteners). The steel groups and strength classes are designated by a four-digit sequence of letters and numbers (eg A2-70) as shown in the following table. DIN EN ISO 3506 governs screws and nuts made from stainless steel.

Steel group	Steel grade	Strength class	Screws, Nuts and Bolts			
			Tensile strength N/mm <sup>2</sup>	Tensile strength PSI	Dia range	Nut Load N/mm <sup>2</sup>
Austenitic	A2 and A4	50	500	70,000	<=M39	500
		70	700	100,000	<=M20	700
		80	800	118,000	<=M20	800

The tensile stress is calculated with reference to the tensile stress area (see DIN EN ISO 3506-1979). Nuts to be paired with same grade of stainless steel screws

Steel group	Property Strength class	Made From	Characteristics
Austenitic	50	A1, A2	Soft; cold worked, turned and soft pressed fasteners
	70	A2, A4	Cold worked, normal strength formed fasteners
	80	A2, A4	Extreme cold worked, high strength, special applications

**2) Chemical composition of stainless steel metric DIN 553 Slotted Set Screws with Cone Point**

Grade	USA Grade	Material designation	Material no.	C %	Si ≤ %	Mn ≤ %	Cr %	Mo %	Ni %
<b>A 2</b>	<b>304</b>	X 5Cr Ni 1810	1.4301	≤ 0.07	1.0	2.0	17.5 to 19.5	-	8.0 to 10.5
		X 2 Cr Ni 1811	1.4306	≤ 0.03	1.0	2.0	18.0 to 20.0	-	10 to 12.0
		X 8 Cr Ni 19/10	1.4303	≤ 0.07	1.0	2.0	17.0 to 19.0	-	11.0 to 13.0
<b>A 4</b>	<b>316</b>	X 5 Cr Ni Mo 1712	1.4401	≤ 0.07	1.0	2.0	16.5 to 18.5	2.0 to 2.5	10.0 to 13.0
		X 2 Cr Ni Mo 1712	1.4404	≤ 0.03	1.0	2.0	16.5 to 18.5	2.0 to 2.5	10 to 13

Aspen Fasteners 4807 Rockside Road, Suite 400, Independence, OH 44131 USA  
[www.aspenfasteners.com](http://www.aspenfasteners.com) | [aspensales@aspenfasteners.com](mailto:aspensales@aspenfasteners.com) | 1-800-479-0056

Headquarters: Independence OH USA; Montreal QC Canada;  
 Distribution Centers: Boston MA; Chicago IL; Cincinnati KY; Dallas TX; Denver CO; Houston TX; Jersey City NJ; Los Angeles CA; Miami FL;  
 San Francisco CA; Seattle WA; Washington VA; Toronto ON; Calgary AB; Vancouver BC; Jiutepec (Temixco); Mexico City; Monterrey

### 3) Chemical composition of steel metric DIN 553 Slotted Set Screws with Cone Point

PROPERTY CLASS	MATERIAL AND TREATMENT	CHEMICAL COMPOSITION LIMITS %				TEMPERING TEMP °C MIN.
		C		P	S	
		min.	max.	max.	max.	
4.6, 4.8, 5.8, 6.8	Low or medium carbon steel	-	0.55	0.05	0.06	-
8.8	Medium carbon steel quenched, tempered	0.25	0.55	0.04	0.05	425
9.8	Medium carbon steel quenched, tempered	0.25	0.55	0.04	0.05	425
10.9	Medium carbon steel additives e.g. boron, Mn, Cr or Alloy steel - quenched, tempered	0.20	0.55	0.04	0.05	425
12.9	Alloy steel - quenched, tempered	0.20	0.50	0.035	0.035	380

### 4) Mechanical properties of steel for metric DIN 553 Slotted Set Screws with Cone Point

MECHANICAL PROPERTY		PROPERTY CLASS								
		4.8	5.6	5.8	6.8	8.8		9.8	10.9	12.9
						Up to M 16	Over M 16			
Tensile Strength (Rm, N/mm <sup>2</sup> )	nom.	400	500		600	800		900	1000	1200
	min.	420	500	520	600	800	830	900	1040	1220
Vickers Hardness	min.	130	155	160	190	250	255	290	320	385
	max.	250				320	336	360	380	435
Brinell Hardness	min.	124	147	152	181	319	242	266	295	353
	max.	238				385	319	342	363	412
Rockwell Hardness	min. HR	71	79	82	89	-				
	HRC	-	-	-	-	20	23	28	32	39
	HR	95			99	-				
	max. HRC	-	-	-	-	32	34	37	39	44
Yield Stress ReL N/mm <sup>2</sup>	nom.	320	300	400	480	-				
	min.	340	300	420	480	-				
Stress at permanent set limit N/mm <sup>2</sup>	nom.	-				640		720	900	1080
	min.	-				640	660	720	940	1100

#### Disclaimer

Dimensional data and technical information for metric DIN 553 Slotted Set Screws with Cone Point was obtained from publicly available sources and not acquired through standards agencies. It has been completed and compiled for reference purposes only; where discrepancies are found they are subject to change without notice. Aspen Fasteners makes no warranties or representations regarding the accuracy and validity of the compiled information and data. Contact the relevant standards authorities for accurate and detailed information.