

Metric ISO 8675 Low Profile Thin Hex Nut Fine Thread

Visit our [online store](#) for product availability

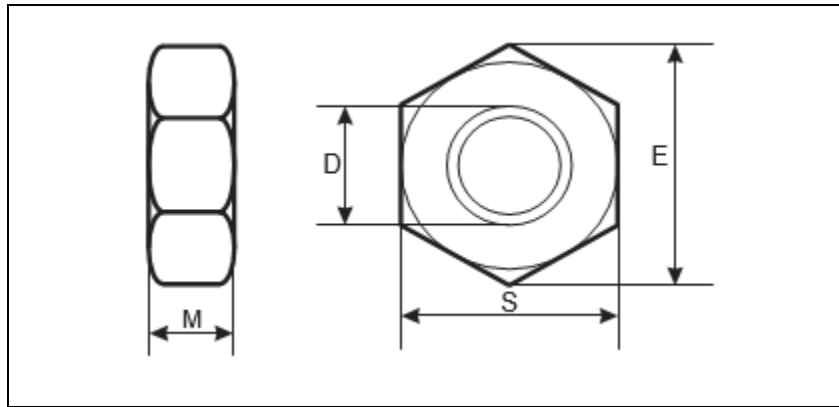

D	S	E	M	WEIGHT IN KG(s) PER 1000 PCS
M8	13	14.38	5	4.0
M10	17	18.90	6	8.6
M12	19	21.10	7	12.1
M14	22	24.49	8	18.2
M16	24	26.75	8	20.1
M18	27	29.56	9	29.6
M20	30	33.53	9	36.3
M24	36	39.98	10	58
M27	40	45.20	12	90
M30	46	51.28	12	111
M33	50	55.37	14	155
M36	55	61.31	14	190
M39	60	66.44	16	260
M42	65	72.61	16	307
M48	75	83.91	18	460

All measurements are in mm

Aspen Fasteners 4807 Rockside Road, Suite 400, Independence, OH 44131 USA
www.aspenfasteners.com | aspensales@aspenfasteners.com | 1-800-479-0056

Headquarters: Independence OH USA; Montreal QC Canada;
 Distribution Centers: Boston MA; Chicago IL; Cincinnati KY; Dallas TX; Denver CO; Houston TX; Jersey City NJ; Los Angeles CA; Miami FL;
 San Francisco CA; Seattle WA; Washington VA; Toronto ON; Calgary AB; Vancouver BC; Jiutepec (Temixco); Mexico City; Monterrey

Metric ISO 8675 Low Profile Thin Hex Nut Fine Thread are thin hex nuts about half as thick as a regular hex nut with similar dimensions to DIN 936. They are often used as lock nuts, where they are threaded up against a standard nut locking it in place or in any circumstance where a standard nut is too thick for an application, a hex jam nut can be a very useful alternative. Aspen Fasteners offers the following sizes for immediate delivery from stock: M8 to M42 in both A2 and marine grade stainless steel as well as brass and steel zinc in right hand and left had threads. Aspen Fasteners offers over 500,000 unique fastener products from stock in inch and metric standard in a variety of materials and finishes. The following sizes of metric ISO 8675 Low Profile Thin Hex Nut Fine Thread are available for immediate shipping from stock: Diameters ranging from M2 to M60 in steel and A2 and marine grade A4 stainless steel. View parts by clicking on the following link: [metric ISO 8675 Low Profile Thin Hex Nut Fine Thread](#).

DIN (**D**eutsches **I**nstitut für **N**ormung - German Institute for Standardization) standards are issued for a variety of components including industrial fasteners as metric DIN 936 Low Profile Hex Nuts. The DIN standards remain common in Germany, Europe and globally even though the transition to ISO standards is taking place. DIN standards continue to be used for parts which do not have ISO equivalents or for which there is no need for standardization. In this case the DIN equivalent for ISO 8675 is DIN 936.

1) Mechanical properties of stainless steel for metric ISO 8675 Low Profile Thin Hex Nut Fine Thread

Stainless steels can be divided into three groups of steel - austenitic, ferritic and martensitic. Austenitic steel is by far the most common type (>90% of commercial fasteners). The steel groups and strength classes are designated by a four-digit sequence of letters and numbers (eg A2-70) as shown in the following table. DIN EN ISO 3506 governs screws and nuts made from stainless steel.

Steel group	Steel grade	Strength class	Screws, Nuts and Bolts			
			Tensile strength N/mm ²	Tensile strength PSI	Dia range	Nut Load N/mm ²
Austenitic	A2 and A4	50	500	70.000	<=M39	500
		70	700	100.000	<=M20	700
		80	800	118.000	<=M20	800

The tensile stress is calculated with reference to the tensile stress area (see DIN EN ISO 3506-1979). Nuts to be paired with same grade of stainless steel screws

Steel group	Property Strength class	Made From	Characteristics
Austenitic	50	A1, A2	Soft; cold worked, turned and soft pressed fasteners
	70	A2, A4	Cold worked, normal strength formed fasteners
	80	A2, A4	Extreme cold worked, high strength, special applications

Aspen Fasteners 4807 Rockside Road, Suite 400, Independence, OH 44131 USA
www.aspenfasteners.com | aspensales@aspenfasteners.com | 1-800-479-0056

2) Chemical composition of stainless steel metric ISO 8675 Low Profile Thin Hex Nut Fine Thread

Grade	USA Grade	Material designation	Material no.	C %	Si ≤ %	Mn ≤ %	Cr %	Mo %	Ni %
A 2	304	X 5Cr Ni 1810	1.4301	≤ 0.07	1.0	2.0	17.5 to 19.5	-	8.0 to 10.5
		X 2 Cr Ni 1811	1.4306	≤ 0.03	1.0	2.0	18.0 to 20.0	-	10 to 12.0
		X 8 Cr Ni 19/10	1.4303	≤ 0.07	1.0	2.0	17.0 to 19.0	-	11.0 to 13.0
A 4	316	X 5 Cr Ni Mo 1712	1.4401	≤ 0.07	1.0	2.0	16.5 to 18.5	2.0 to 2.5	10.0 to 13.0
		X 2 Cr Ni Mo 1712	1.4404	≤ 0.03	1.0	2.0	16.5 to 18.5	2.0 to 2.5	10 to 13

3) Chemical composition of steel metric ISO 8675 Low Profile Thin Hex Nut Fine Thread

PROPERTY CLASS	MATERIAL AND TREATMENT	CHEMICAL COMPOSITION LIMITS %				TEMPERING TEMP °C MIN.
		C		P	S	
		min.	max.	max.	max.	
4.6. 4.8. 5.8. 6.8	Low or medium carbon steel	-	0.55	0.05	0.06	-
8.8	Medium carbon steel quenched. tempered	0.25	0.55	0.04	0.05	425
9.8	Medium carbon steel quenched. tempered	0.25	0.55	0.04	0.05	425
10.9	Medium carbon steel additives e.g. boron. Mn. Cr or Alloy steel - quenched. tempered	0.20	0.55	0.04	0.05	425
12.9	Alloy steel - quenched. tempered	0.20	0.50	0.035	0.035	380

Aspen Fasteners 4807 Rockside Road, Suite 400, Independence, OH 44131 USA
www.aspenfasteners.com | aspensales@aspenfasteners.com | 1-800-479-0056

4) Mechanical properties of steel for metric ISO 8675 Low Profile Thin Hex Nut Fine Thread

MECHANICAL PROPERTY		PROPERTY CLASS								
		4.8	5.6	5.8	6.8	8.8		9.8	10.9	12.9
						Up to M 16	Over M 16			
Tensile Strength (Rm. N/mm ²)	nom.	400	500		600	800		900	1000	1200
	min.	420	500	520	600	800	830	900	1040	1220
Vickers Hardness	min.	130	155	160	190	250	255	290	320	385
	max.	250				320	336	360	380	435
Brinell Hardness	min.	124	147	152	181	319	242	266	295	353
	max.	238				385	319	342	363	412
Rockwell Hardness	min. HR	71	79	82	89	-				
	HRC	-	-	-	-	20	23	28	32	39
	HR	95			99	-				
	max. HRC	-	-	-	-	32	34	37	39	44
Yield Stress ReL. N/mm ²	nom.	320	300	400	480	-				
	min.	340	300	420	480	-				
Stress at permanent set limit N/mm ²	nom.	-				640		720	900	1080
	min.	-				640	660	720	940	1100

Disclaimer

Dimensional data and technical information for metric ISO 8675 Low Profile Thin Hex Nut Fine Thread was obtained from publicly available sources and not acquired through standards agencies. It has been completed and compiled for reference purposes only; where discrepancies are found they are subject to change without notice. Aspen Fasteners makes no warranties or representations regarding the accuracy and validity of the compiled information and data. Contact the relevant standards authorities for accurate and detailed information.