

Metric DIN 7981 Cross Recessed Pan Head Tapping Screws

Visit our [online store](#) for product availability

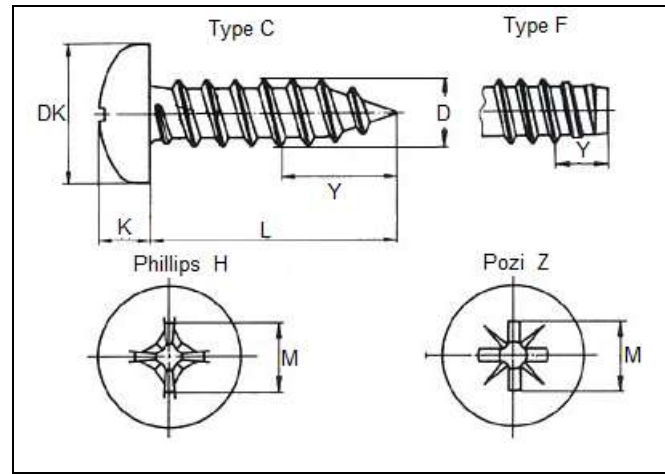

Dimensions of Metric DIN 7981 Cross Recessed Pan Head Tapping Screws

Thread size			2.2	2.9	3.5	(3.9)	4.2	4.8	5.5	6.3
P			0.8	1.1	1.3	1.3	1.4	1.6	1.8	1.8
a	max.		0.8	1.1	1.3	1.3	1.4	1.6	1.8	1.8
DK	nominal=max.		4.2	5.6	6.9	7.5	8.2	9.5	10.8	12.5
	min.		3.9	5.3	6.54	7.14	7.84	9.14	10.37	12.07
K	nominal=max.		1.8	2.2	2.6	2.8	3.05	3.55	3.95	4.55
	min.		1.55	1.95	2.35	2.55	2.75	3.25	3.65	4.25
Cross recess		No.	1	1	2	2	2	2	3	3
Type H	m	approx.	2.6	3	4.2	4.4	4.6	5	6.5	7.1
	Penetration depth	min.	0.86	1.35	1.4	1.63	1.8	2.26	2.49	3
		max.	1.32	1.8	2.03	2.26	2.46	2.87	3.15	3.66
Type Z	m	approx.	2.4	2.9	3.9	4.1	4.3	4.7	6.2	6.7
	Penetration depth	min.	1.1	1.58	1.47	1.7	1.88	2.28	2.51	3.02
		max.	1.35	1.83	1.93	2.16	2.34	2.74	2.97	3.48
y	max.	Type C	2	2.6	3.2	3.5	3.7	4.3	5	6
		Type F	1.6	2.1	2.5	2.7	2.8	3.2	3.6	3.6

Aspen Fasteners 4807 Rockside Road, Suite 400, Independence, OH 44131 USA
www.aspenfasteners.com | aspensales@aspenfasteners.com | 1-800-479-0056

Weight of Metric DIN 7981 Cross Recessed Pan Head Tapping Screws

L nominal	Type C		Type F		Weight kg/1000 pcs								
	min.	max.	min.	max.									
4.5	3.7	5.3	3.7	4.5	0.174								
6.5	5.7	7.3	5.7	6.5	0.214	0.424							
9.5	8.7	10.3	8.7	9.5	0.274	0.532	0.84	1.07	1.26	1.85			
13	12.2	13.8	12.2	13	0.344	0.658	1.02	1.29	1.5	2.18	3.24	4.32	
16	15.2	16.8	15.2	16	0.404	0.766	1.17	1.48	1.71	2.46	3.62	4.86	
19	18.2	19.8	18.2	19		0.874	1.32	1.67	1.92	2.74	4	5.4	
22	21.2	22.8	20.7	22			1.47	1.86	2.13	3.02	4.38	5.94	
25	24.2	25.8	23.7	25			1.62	2.05	2.34	3.3	4.76	6.48	
32	30.7	33.3	30.7	32					2.83	3.96	5.67	7.74	
38	36.7	39.3	36.7	38						4.52	6.45	8.82	

Metric DIN 7981C is a pan head self-tapping sheet metal screws These screws are designed to cut threads into pre-drilled untapped holes of the substrate into which they are screwed. The recommended pilot hole sizes vary, depending on the diameter of the screw to be used and thickness of the substrate material. These screws are available in zinc plated steel as well as stainless steel A2 and A4. Metric DIN 7981C pan head self-tapping sheet metal screws are fully threaded with a coarse thread and a gimlet point (Form C). Recommended to be used in thin gauge sheet metal, resinous plywood, and composite materials. The pan head is cylindrical with a slightly rounded top surface and a flat bearing surface underneath. This head style is ideal for most applications where a protruding head is acceptable. Aspen Fasteners offers over 500,000 unique fastener products from stock in inch and metric standard in a variety of materials and finishes. The following sizes metric DIN 7981C pan head self-tapping sheet metal screws are available for immediate shipping from stock: Diameters ranging from M2.2 to M6.3 up to 38mm long in zinc plated steel and stainless steel A2 and A4. View parts by clicking on the following link: [DIN 7981 pan head self-tapping sheet metal screws](#)

DIN (Deutsches Institut für Normung - German Institute for Standardization) standards are issued for a variety of components including industrial fasteners as metric DIN 7981C pan head self-tapping sheet metal screws. The DIN standards remain common in Germany, Europe and globally even though the transition to ISO standards is taking place. DIN standards continue to be used for parts which do not have ISO equivalents or for which there is no need for standardization. The ISO equivalent of a metric DIN 7981C pan head self-tapping sheet metal screws is ISO 7049.

1) Mechanical properties of stainless steel for metric DIN 7981 pan head self-tapping sheet metal screws

Stainless steels can be divided into three groups of steel - austenitic, ferritic and martensitic. Austenitic steel is by far the most common type (>90% of commercial fasteners). The steel groups and strength classes are designated by a four-digit sequence of letters and numbers (eg A2-70) as shown in the following table. DIN EN ISO 3506 governs screws and nuts made from stainless steel.

Steel group	Steel grade	Strength class	Screws, Nuts and Bolts			
			Tensile strength N/mm ²	Tensile strength PSI	Dia range	Nut Load N/mm ²
Austenitic	A2 and A4	50	500	70.000	<=M39	500
		70	700	100.000	<=M20	700
		80	800	118.000	<=M20	800

The tensile stress is calculated with reference to the tensile stress area (see DIN EN ISO 3506-1979). Nuts to be paired with same grade of stainless steel screws

Steel group	Property Strength class	Made From	Characteristics
Austenitic	50	A1, A2	Soft; cold worked, turned and soft pressed fasteners
	70	A2, A4	Cold worked, normal strength formed fasteners
	80	A2, A4	Extreme cold worked, high strength, special applications

2) Chemical composition of stainless steel metric DIN 7981 pan head self-tapping sheet metal screws

Grade	USA Grade	Material designation	Material no.	C %	Si ≤ %	Mn ≤ %	Cr %	Mo %	Ni %
A 2	304	X 5Cr Ni 1810	1.4301	≤ 0.07	1.0	2.0	17.5 to 19.5	-	8.0 to 10.5
		X 2 Cr Ni 1811	1.4306	≤ 0.03	1.0	2.0	18.0 to 20.0	-	10 to 12.0
		X 8 Cr Ni 19/10	1.4303	≤ 0.07	1.0	2.0	17.0 to 19.0	-	11.0 to 13.0
A 4	316	X 5 Cr Ni Mo 1712	1.4401	≤ 0.07	1.0	2.0	16.5 to 18.5	2.0 to 2.5	10.0 to 13.0
		X 2 Cr Ni Mo 1712	1.4404	≤ 0.03	1.0	2.0	16.5 to 18.5	2.0 to 2.5	10 to 13

3) Chemical composition of steel metric DIN 7981 pan head self-tapping sheet metal screws

PROPERTY CLASS	MATERIAL AND TREATMENT	CHEMICAL COMPOSITION LIMITS %				TEMPERING TEMP °C MIN.
		C		P	S	
		min.	max.	max.	max.	
4.6. 4.8. 5.8. 6.8	Low or medium carbon steel	-	0.55	0.05	0.06	-
8.8	Medium carbon steel quenched. tempered	0.25	0.55	0.04	0.05	425
9.8	Medium carbon steel quenched. tempered	0.25	0.55	0.04	0.05	425
10.9	Medium carbon steel additives e.g. boron. Mn. Cr or Alloy steel - quenched. tempered	0.20	0.55	0.04	0.05	425
12.9	Alloy steel - quenched. tempered	0.20	0.50	0.035	0.035	380

4) Mechanical properties of steel for metric DIN 7981 pan head self-tapping sheet metal screws

MECHANICAL PROPERTY		PROPERTY CLASS									
		4.8	5.6	5.8	6.8	8.8		9.8	10.9	12.9	
						Up to M 16	Over M 16				
Tensile Strength (Rm. N/mm ²)	nom.	400	500		600	800		900	1000	1200	
	min.	420	500	520	600	800	830	900	1040	1220	
Vickers Hardness	min.	130	155	160	190	250	255	290	320	385	
	max.	250				320	336	360	380	435	
Brinell Hardness	min.	124	147	152	181	319	242	266	295	353	
	max.	238				385	319	342	363	412	
Rockwell Hardness	min. HR	71	79	82	89	-					
	HRC	-	-	-	-	20	23	28	32	39	
	HR	95				99	-				
	max. HRC	-	-	-	-	32	34	37	39	44	
Yield Stress ReL. N/mm ²	nom.	320	300	400	480	-					
	min.	340	300	420	480	-					
Stress at permanent set limit N/mm ²	nom.	-				640		720	900	1080	
	min.	-				640	660	720	940	1100	

Disclaimer

Dimensional data and technical information for metric DIN 7981 pan head self-tapping sheet metal screws was obtained from publicly available sources and not acquired through standards agencies. It has been completed and compiled for reference purposes only; where discrepancies are found they are subject to change without notice. Aspen Fasteners makes no warranties or representations regarding the accuracy and validity of the compiled information and data. Contact the relevant standards authorities for accurate and detailed information.